

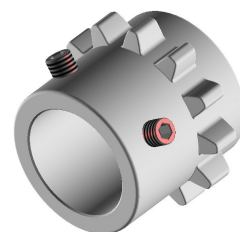

**Ingranaggio GS zinc.**

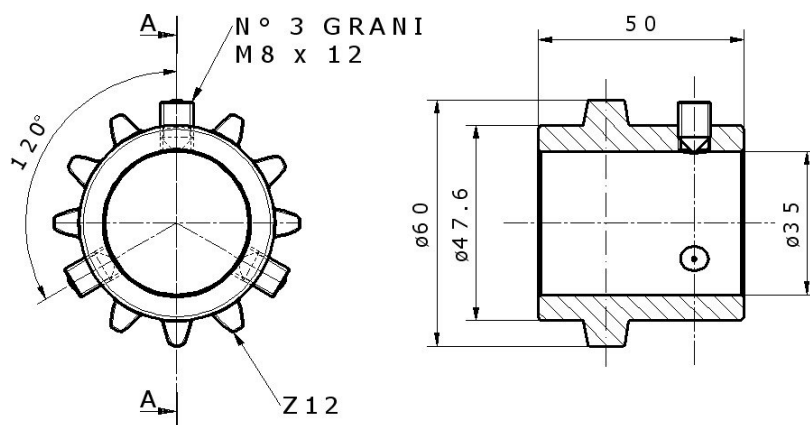

Ingranaggio per cremagliera in ghisa G25, zincatura elettrolitica bianca.  
Applicabilità su cuffia: E1039.1, E1039.2, E0473.0  
Applicabilità su asta forata: C0468, C0584, C0469.

CODICE	DESCRIZIONE	F (N)	Kg
C0452.1	Ingranaggio GS	1500	0,30



### Ingranaggio OT

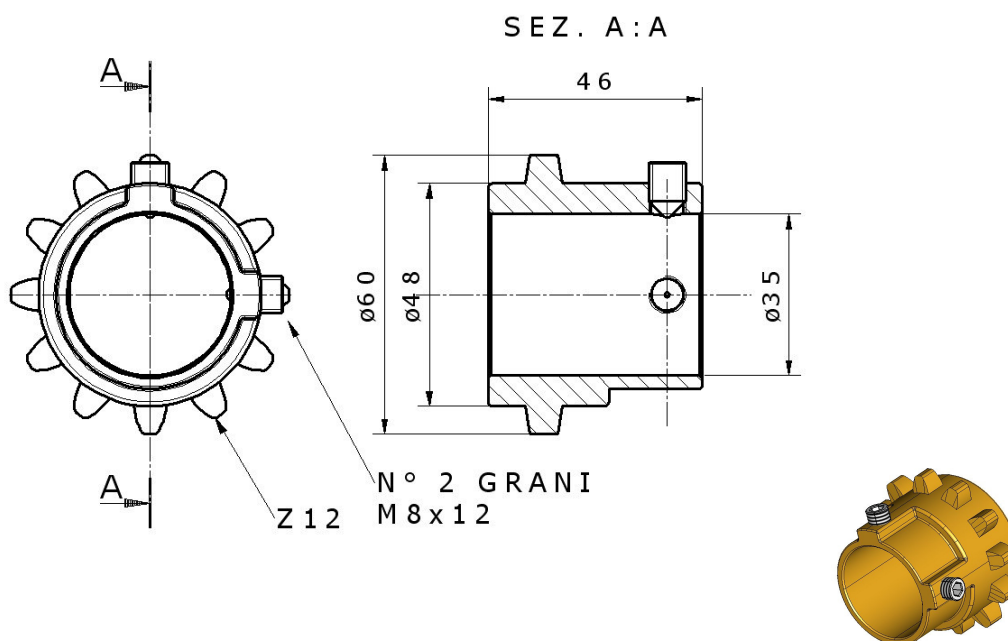

Ingranaggio per cremagliera in ottone stampato.  
Applicabilità su cuffia: E1039.0, E1039.1, E1039.2.  
Applicabilità su asta forata: C0468, C0584, C1037, C1038.

CODICE	DESCRIZIONE	F (N)	Kg
C0452.2	Ingranaggio OT	700	0,28