

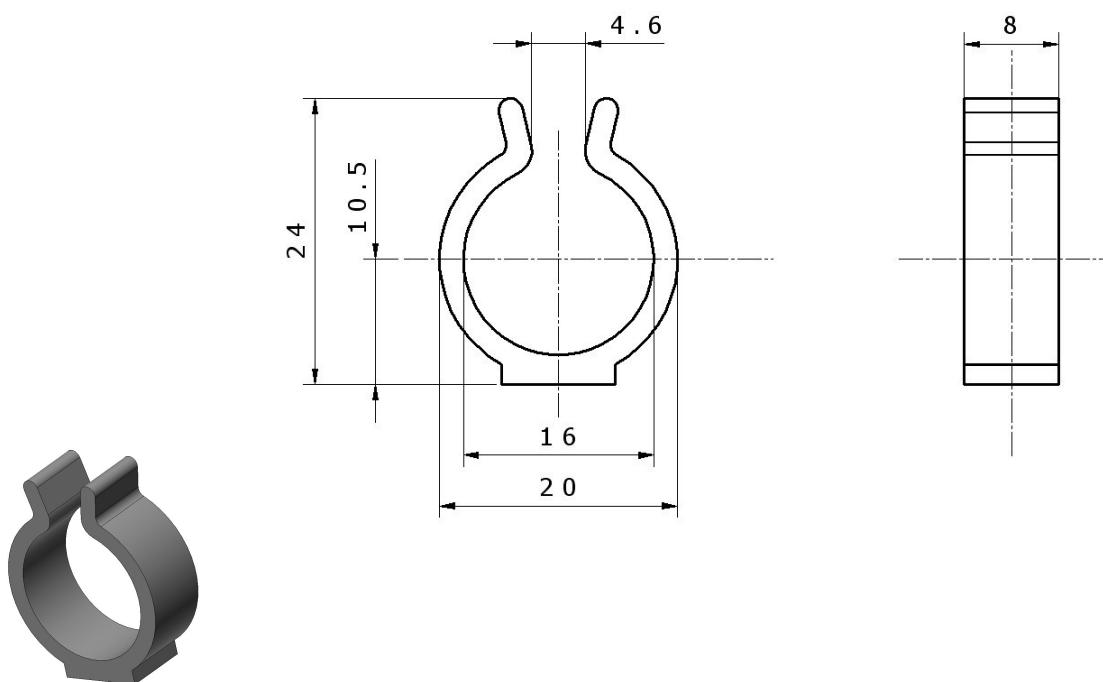

**Accessori per schermi—Clips**



Clips diametro 16.  
Stampata in materiale termoplastico (Ostaform).

CODICE	DESCRIZIONE	Kg
C0617.1	Clips	0,002

Il prezzo di listino indicato si riferisce al costo di 100 pezzi



**Accessori per schermi—Passafilo**

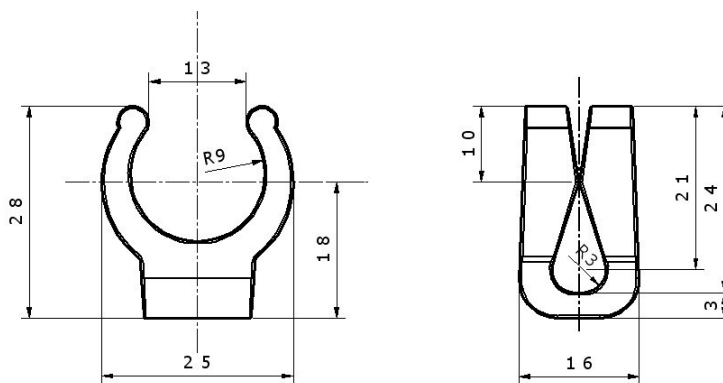

Passafilo diametro 19.  
Stampata in materiale termoplastico (Ostaform).

CODICE	DESCRIZIONE	Kg
C0619.1	Passafilo	0,004

Il prezzo di listino indicato si riferisce al costo di 100 pezzi



**Accessori per schermi—Pinza per telo**

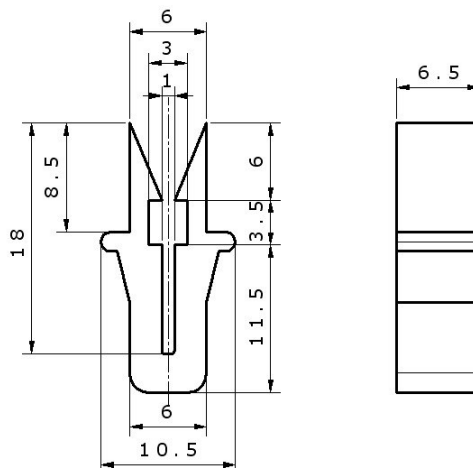
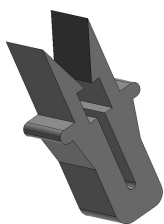

Pinza per telo.  
Stampata in materiale termoplastico (Ostaform).

CODICE	DESCRIZIONE	Kg
C0620.1	Pinza per telo	0,0005

Il prezzo di listino indicato si riferisce al costo di 100 pezzi



**Accessori per schermi—Gancio “S”**

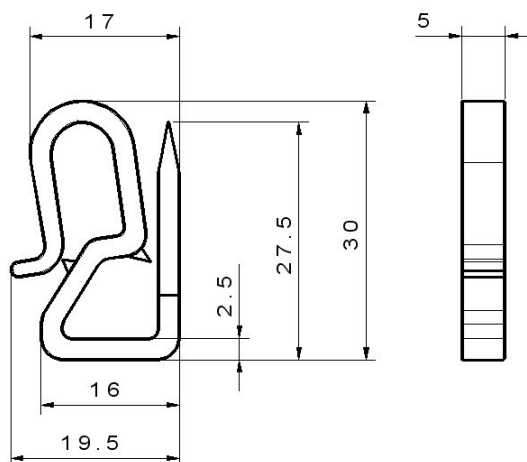

Gancio a “S”.  
Stampata in materiale termoplastico (Ostaform).

CODICE	DESCRIZIONE	Kg
C0621.1	Gancio a “S”	0,002

Il prezzo di listino indicato si riferisce al costo di 100 pezzi



**Accessori per schermi—Rullo**

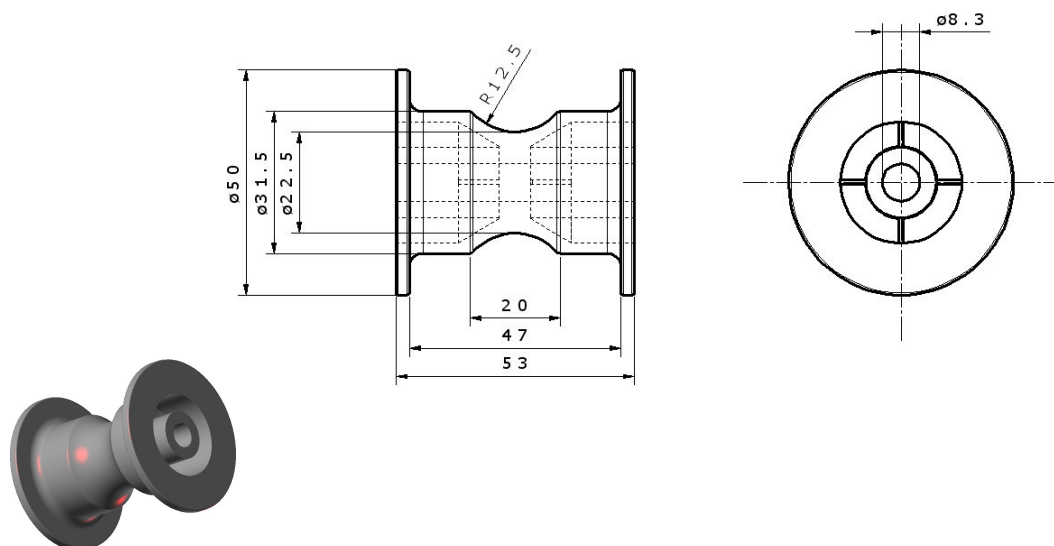

Rullo.  
Stampata in materiale termoplastico (Ostaform).

CODICE	DESCRIZIONE	Kg
C0612.1	Rullo	0,03



**Accessori per schermi—Staffa per rullo**

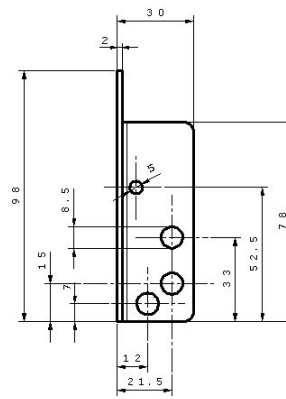
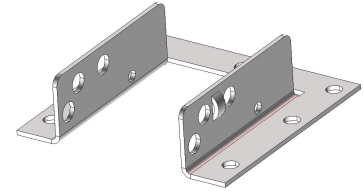
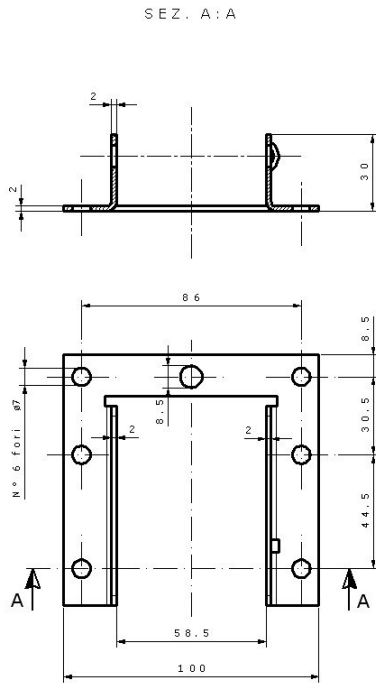

Staffa per rullo.

Realizzata in acc. Zincato Sendzimir, a richiesta può essere fornita zincata a caldo.

CODICE	DESCRIZIONE	Kg
C0611.1	Staffa per rullo	0,13



**Accessori per schermi-Staffa con rullo**

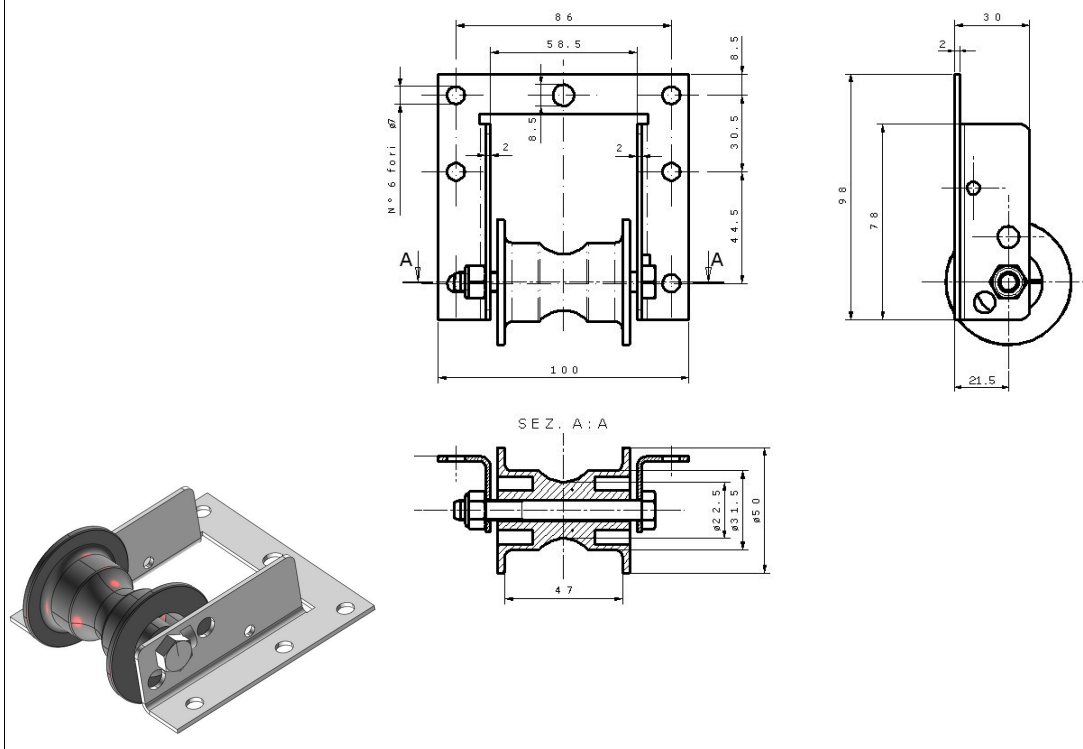

Staffa con rullo.  
A richiesta può essere fornita con staffa zincata  
a caldo e bulloneria inox.

CODICE	DESCRIZIONE	Kg
E0630.9	Staffa con rullo	0,20



**Accessori per schermi—Giunto a snodo**

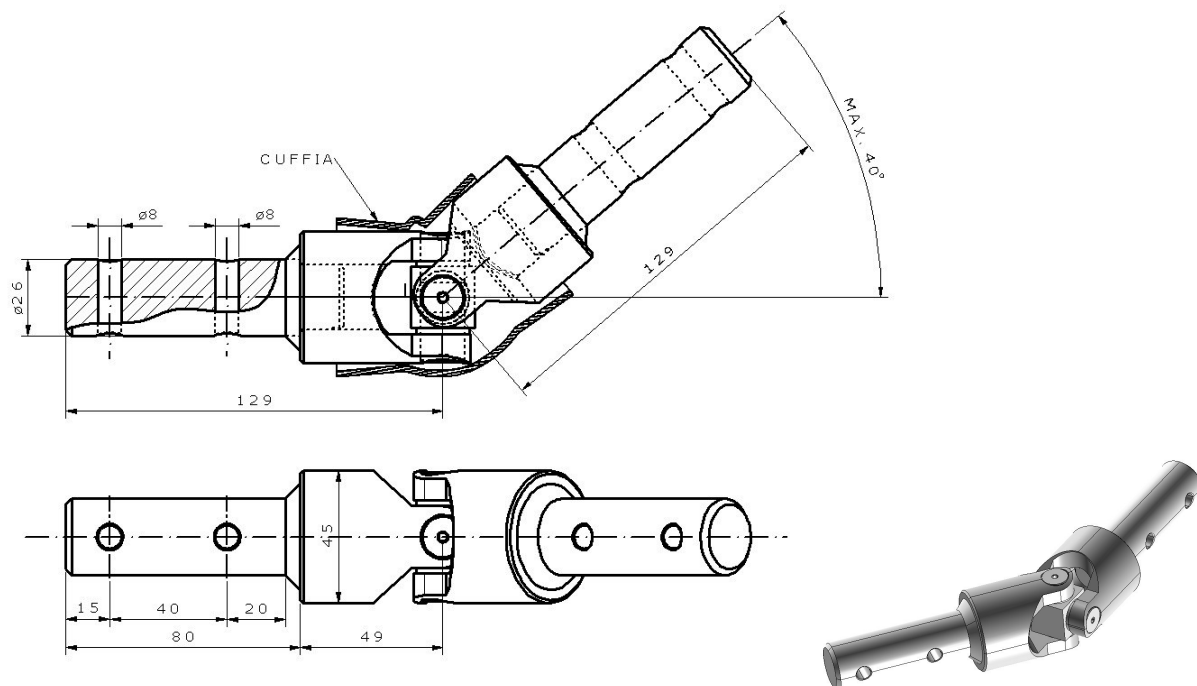

Giunto a snodo.  
Fornito con cuffia di protezione.

CODICE	DESCRIZIONE	Kg
E0903.1	Giunto a snodo	1,50